

CENTRAL MACHINERY

®

8" X 12" LATHE

Model 44859

ASSEMBLY AND OPERATING INSTRUCTIONS

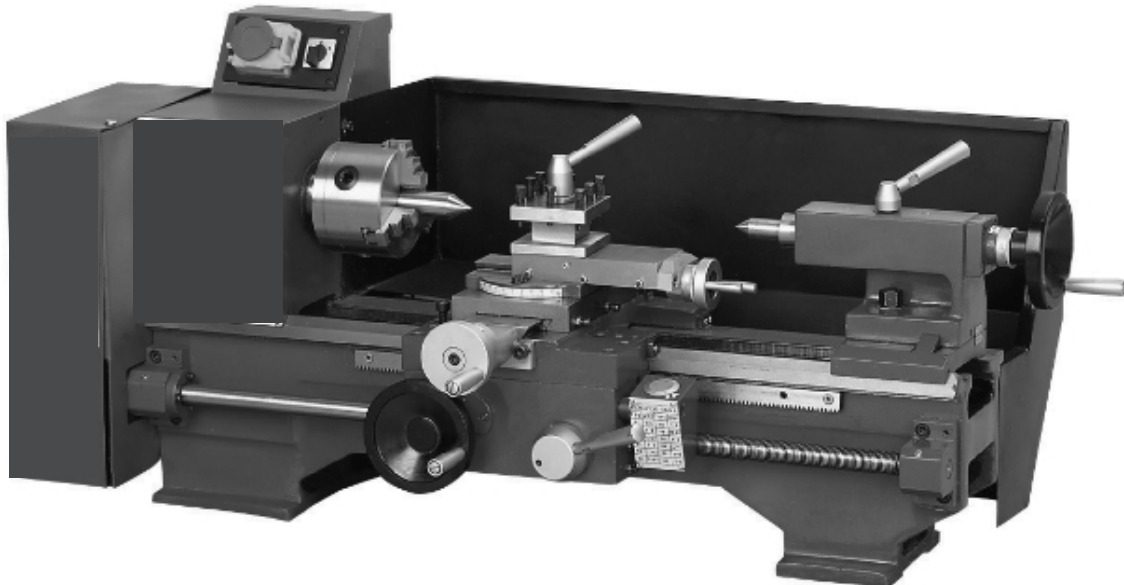

Distributed exclusively by Harbor Freight Tools®.
3491 Mission Oaks Blvd., Camarillo, CA 93011
Visit our website at: <http://www.harborfreight.com>



**Read this material before using this product.
Failure to do so can result in serious injury.
SAVE THIS MANUAL.**

Copyright© 2001 by Harbor Freight Tools®. All rights reserved. No portion of this manual or any artwork contained herein may be reproduced in any shape or form without the express written consent of Harbor Freight Tools. Diagrams within this manual may not be drawn proportionally. Due to continuing improvements, actual product may differ slightly from the product described herein. Tools required for assembly and service may not be included.

For technical questions or replacement parts, please call 1-800-444-3353.

Revised 09g

Specifications

ITEM	DESCRIPTION
Power	110VAC, 60 Hz, 550 watts
Motor	3/4 HP
Distance between Centers	12 inches
Swing over Bed	8 inches
Spindle Step Speeds	125, 210, 420, 620, 1000, 2000 RPM
Spindle Bore	3/4 inch
Spindle Taper	MT3
Tailstock Taper	MT2
Chuck Capacity	4 inch, 3-jaw; reversing jaws
Cross Slide Travel	4-1/2 inches
Tool Slide Travel	2-3/4 inches
Slide Scale	0.001 inch per mark tool
Metric Thread Pitches	10 (0.4 ~ 3.0 mm)
SAE Thread Pitches	12 (8 ~ 40 TPI)
Accessories	<ul style="list-style-type: none"> - 3 reverse jaws for chuck - Chuck wrench - Dead centers MT2 and MT3 - Wrenches: 10-12 open end, 14-17 open end 17-19 open end, 45-52 round nut, tool post - Hex wrenches: 3, 4, 5, 6mm - 2 Drive Belts - Threading gear set
Weight	254 lb.

NOTE: The Splash Guard shown in the cover page photo is not included. It can be ordered from Harbor Freight Tools using SKU 26962.

Save This Manual

You will need the manual for the safety warnings and precautions, assembly instructions, operating and maintenance procedures, parts list and diagram. Keep your invoice with this manual. Write the invoice number on the inside of the front cover. Keep the manual and invoice in a safe and dry place for future reference.

Safety Warnings and Precautions

WARNING: When using tool, basic safety precautions should always be followed to reduce the risk of personal injury and damage to equipment.

Read all instructions before using this tool!

1. **Keep work area clean.** Cluttered areas invite injuries.
2. **Observe work area conditions.** Do not use machines or power tools in damp or wet locations. Don't expose to rain. Keep work area well lighted. Do not use electrically powered tools in the presence of flammable gases or liquids.

3. **Keep children away.** Children must never be allowed in the work area. Do not let them handle machines, tools, or extension cords.
4. **Store idle equipment.** When not in use, tools must be stored in a dry location to inhibit rust. Always lock up tools and keep out of reach of children.
5. **Do not force tool.** It will do the job better and more safely at the rate for which it was intended. Do not use inappropriate attachments in an attempt to exceed the tool capacity.
6. **Use the right tool for the job.** Do not attempt to force a small tool or attachment to do the work of a larger industrial tool. There are certain applications for which this tool was designed. Do not modify this tool and do not use this tool for a purpose for which it was not intended.
7. **Dress properly.** Do not wear loose clothing or jewelry as they can be caught in moving parts. Protective, electrically non-conductive clothes and non-skid footwear are recommended when working. Wear restrictive hair covering to contain long hair.
8. **Use eye and ear protection.** Always wear ANSI approved impact safety goggles. Wear a full face shield if you are producing metal filings or wood chips. Wear an ANSI approved dust mask or respirator when working around metal, wood, and chemical dusts and mists.
9. **Do not overreach.** Keep proper footing and balance at all times. Do not reach over or across running machines.
10. **Maintain tools with care.** Keep tools sharp and clean for better and safer performance. Follow instructions for lubricating and changing accessories. Inspect tool cords periodically and, if damaged, have them repaired by an authorized technician. The handles must be kept clean, dry, and free from oil and grease at all times.
11. **Disconnect power.** Unplug tool when not in use.
12. **Remove adjusting keys and wrenches.** Check that keys and adjusting wrenches are removed from the tool or machine work surface before plugging it in.
13. **Avoid unintentional starting.** Be sure the switch is in the Off position when not in use and before plugging in.
14. **Stay alert.** Watch what you are doing, use common sense. Do not operate any tool when you are tired.
15. **Check for damaged parts.** Before using any tool, any part that appears damaged should be carefully checked to determine that it will operate properly and perform its intended function. Check for alignment and binding of moving parts; any broken parts or mounting fixtures; and any other condition that may affect proper operation. Any part that is damaged should be properly repaired or replaced by a qualified technician. Do not use the tool if any switch does not turn On and Off properly.
16. **Guard against electric shock.** Prevent body contact with grounded surfaces such as pipes, radiators, ranges, and refrigerator enclosures.
17. **Replacement parts and accessories.** When servicing, use only identical

replacement parts. Use of any other parts will void the warranty. Only use accessories intended for use with this tool. Approved accessories are available from Harbor Freight Tools.

18. **Do not operate tool if under the influence of alcohol or drugs.** Read warning labels on prescriptions to determine if your judgment or reflexes are impaired while taking drugs. If there is any doubt, do not operate the tool.
19. **Use proper size and type extension cord.** If an extension cord is required, it must be of the proper size and type to supply the correct current to the tool without heating up. Otherwise, the extension cord could melt and catch fire, or cause electrical damage to the tool. This tool requires use of an extension cord of **0 to 12 amps** capability (up to 50 feet), with wire size rated at **16 AWG**. Longer extension cords require larger size wire. If you are using the tool outdoors, use an extension cord rated for outdoor use (signified by “WA” on the jacket).
21. **Maintenance.** For your safety, service and maintenance should be performed regularly by a qualified technician.
22. **Know your power tool.** Read and understand this assembly and operating manual, and labels affixed to the tool. Learn it’s application and limitations, as well as the specific potential hazards particular to this tool.
23. **Ground the tool.** This tool is equipped with an approved 3-conductor cord and 3-prong grounding type plug to fit a grounding type receptacle. The green wire in the cord is the grounding wire. Never connect the green wire to a live terminal.
24. **Use safety guards.** Keep guards in place, in working order, and in proper adjustment and alignment.
25. **Secure workpiece.** Use clamps or a vise to hold workpiece when practical. Keep both hands free to operate tool.
26. **Direction of Feed.** Feed workpiece into the blade or cutter against the direction of the rotation.

Note: Performance of this tool may vary depending on variations in local line voltage. Extension cord usage may also affect tool performance.

Warning: The warnings, cautions, and instructions discussed in this instruction manual cannot cover all possible conditions and situations that may occur. It must be understood by the operator that common sense and caution are factors which cannot be built into this product, but must be supplied by the operator.

Unpacking

When unpacking, check to make sure that all the parts are included. Refer to the Accessories list in the Specifications table, and the Parts List.

If any parts are missing or broken, please call Harbor Freight Tools at the number on the cover of this manual as soon as possible.

Installation

1. Carefully place the Lathe on a sturdy, level work table with sufficient light.
2. Use appropriate hardware (not included) in the mounting holes of the lathe base, to properly secure the lathe. The work table must also be properly mounted to the floor.
3. Before operation, verify that the slide, worktable, and spindle can move, and are not locked in place.
4. Clean machine with nonflammable solvent and oil the machine according to the lubrication requirements (see Lubrication section) before running the machine.

Operation

This 8 x 12 inch Lathe is capable of machining metal and nonmetallic stock by cutting, drilling, and milling. It can cut circular surfaces, both inside and out, cones, mill planes or grooves, and other cutting functions depending on the tools used. It can also create SAE and metric threads.

Controls

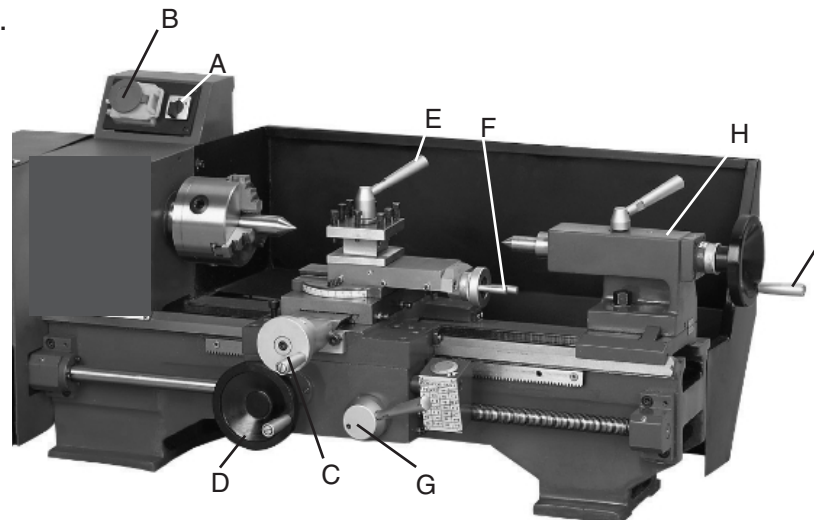

NOTE: The Splash Guard shown in the photo above is not included. It can be ordered using SKU 26962.

ITEM	NAME	USAGE	ASSY NO.
A	Reversing Switch	Change rotation direction of the spindle	200
B	Master Switch	Turn machine power On and Off	200
C	Turn Lever	Moves saddle transversely	500
D	Turn Lever	Moves saddle longitudinally	600
E	Straight Lever	Clamps the square tool rest	400
F	Straight Lever	Moves the square tool rest carriage longitudinally	400
G	Straight Lever	Controls apron clasp nut	600
H	Straight Lever	Controls tailstock sleeve	300
I	Turn Lever	Moves tailstock sleeve longitudinally	300

Lathe Safety Precautions

1. Keep fingers away from revolving parts and cutting tools while in operation.
2. Never force cutting action.
3. Never perform an abnormal or little used operation without study and use of adequate blocks, jigs, stops, and fixtures.
4. Verify proper cutting speed for the material being cut, and any special operation, in a machinery shop handbook.
5. Do not open drive cover while in operation.
6. Always remove chuck key from chuck.
7. Do not attempt to adjust or remove tools when lathe is in operation.
8. Always keep cutting tools sharp.

Cutting Procedures

The instructions that follow are basic operational procedures. It is assumed that the operator understands lathe operation and its capabilities.

1. Rotate Turn Lever (C) counterclockwise to move the saddle outward.
2. Place the workpiece in the chuck, center, and secure with the chuck key.
3. Loosen the Straight Lever (H) and then rotate the Turn Lever (I) clockwise to engage the Dead Center tool into the end of the workpiece. Tighten Straight Lever (H) again.
4. Select the desired tool set and place it into the tool rest. Align the tool nose to the spindle centerline, then tighten.
5. Open the Gear Box and verify that the proper speed is engaged.

Typically, the harder the metal workpiece, the faster the spindle speed.

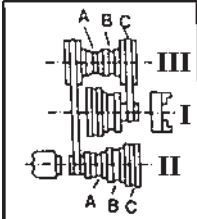
	Spindle RPM		
	A	B	C
II-I	620	1000	2000
III-I	125	210	420

6. Set the desired feed amount according to the type of stock, workpiece dimensions, and the type of cut.
7. Close the Gear Box.
8. Open the safety cover over the On / Off switch and press the green On button.
Verify that the lathe head and feed amount is correct.
9. Align the tool nose on the workpiece where the cut is to begin.
10. Rotate the Turn Lever (C) clockwise to move the saddle transversely, moving the tool nose into the workpiece for cutting.
11. When the cut is complete, press the red Off button.

Machining Cylinders

1. Repeat the cutting procedure steps 1 through 8, listed on the previous page.
2. Rotate Turn Lever (D) clockwise and move the saddle to the right of the workpiece.
3. Rotate Turn Lever (C) clockwise until the desired depth of cut is reached on the far right surface of the work piece.
4. Press down on the Straight Lever (G) to engage apron clasp nut over the Gear Shaft.
The tool will automatically move from right to left while cutting the workpiece.
5. When the cut is complete, press the red Off button.
Optionally, you can turn the Reverse switch to have the tool go over the same cut in the opposite direction (left-to-right). This will clean and smooth the previous cut.
6. When the cut is complete, press the red Off button.

Machining Cones

Manually

This operation is similar to machining cylinders with the following differences.

1. To manually cut a cone, determine the taper requirement and turn the small cutter rest to the desired slope on the workpiece. Retighten the cutter rest.
2. Press the green On button to start the lathe.
3. Turn the Straight Lever (F) clockwise to make the cut.

Automatically

1. To automatically cut a cone, determine the taper requirement and turn the small cutter rest to the desired slope on the workpiece. Retighten the cutter rest.
2. Horizontally move the tailstock from the spindle centerline to the required slope on the far right surface of the work piece.
3. Press the green On button to start the lathe.
4. Press down on the Straight Lever (G) to engage apron clasp nut over the Gear Shaft.
The tool will automatically move from right to left while cutting the workpiece.
5. Repeat steps 2 through 4 until the desired cone size is cut.
6. When the cut is complete, press the red Off button.

Machining Threads

The Gear Box is composed of the change gears, shaft bolt, fixing shaft bolt, and square nut. The change gear box is fixed on the left support of the leadscrew (101). To cut threads, select the proper change gears for the desired thread type (see Thread Formula Table), and engage with approximately 0.1 mm tolerance. Tighten Screw (835).

The Fixed Shaft Bolt (825) under the spindle is used for right hand cutting and threading. The set of Fixed Shaft Bolts in the accessory kit is used in combination with the original set of Shaft Bolts to reverse the rotation of the long leadscrew for left-handed threading and cutting.

The change gear for metric or inch threading is selected according to the Thread to Gear formula and table. The feed amount depends on the material to be cut, the surface roughness, and finish requirements. If the two settings "0.1 and 0.2", of the Gear table do not meet the requirement, you can add or change gears. The same is true if the number of teeth listed in the Gear table do not coincide with the calculated number of teeth. In this case, use gears with similar number of teeth. In doing so, however, the following relationship of the driving shaft must be met: $Z_3+Z_4 > Z_2+Z_5$. Otherwise, the addendum of circles A_2 and Z_5 will hit each other.

The left formula below is an example of 0.3 mm spindle round. The right formula is an example for 8 threads per inch.

eg: request feed distance 0.3/spindle round

Given: spindle gear $Z=40$

$$\text{Feed Distance} = \frac{Z_1}{Z_2} \times \frac{Z_3}{Z_4} \times \frac{Z_5}{Z_6} \times t$$

Screw Distance $t=2$

$$\text{Solution: } \frac{0.3}{2} = \frac{10 \times 1.5 \times 2}{20 \times 2 \times 5} = \frac{40}{80} \times \frac{60}{80} \times \frac{30}{75}$$

$$\text{Feed Distance } \frac{40}{80} \times \frac{60}{80} \times \frac{30}{75} \times 2 = \frac{60}{200} = 0.3(\text{mm})$$

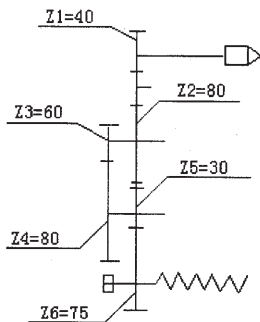

eg: request feed distance 8TPI

Given: spindle gear $Z=40$

$$\text{Feed Distance} = \frac{Z_1}{Z_2} \times \frac{Z_3}{Z_4} \times \frac{Z_5}{Z_6} \times t$$

Screw Distance $t=12\text{TPI}$

$$\text{Solution: } \frac{12}{8} = \frac{40}{80} \times \frac{80}{40} \times \frac{75}{50}$$

$$\text{Feed Distance } 12 \div \left(\frac{40}{80} \times \frac{80}{40} \times \frac{75}{50} \right) = 8(\text{TPI})$$

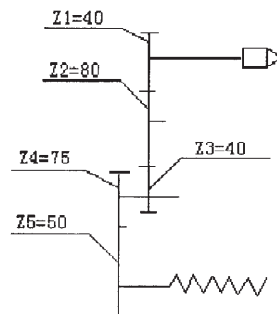

The Thread to Gear settings table on the following page allows you to select the number of threads per inch or millimeter, and which gears need to be used.

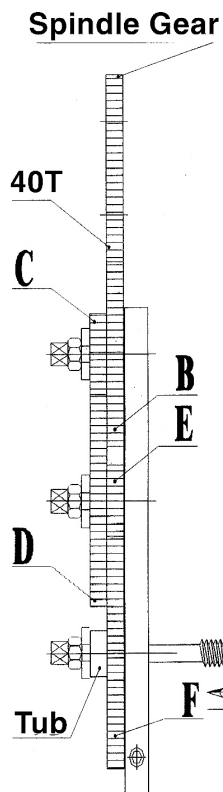

Thread to Gear Settings

1"/n	8	9	10	11	12	14
B	80	90	70	70	70	70
D	E 75 40	60 40	72 40	72 40	72	60 40
F	50	45	60	66	40	70
1"/n	16	18	20	24	32	40
B	70	70	70	70	70	70
D	E 60 40	60 80	60 80	50 40	45 80	30 40
F	80	45	50	100	60	100
mm	0.4	0.5	0.6	0.7	0.8	1
C	B 68 80	68 80	68 80	68 40	68 80	68 80
D	E 72 30	72 35	72 45	72 35	72 48	60
F	75	70	75	100	60	72
mm	1.25	1.5	1.75	2	2.5	3
C	B 68 80	68 80	68 80	68 80	68 80	68 80
D	E 72 60	72 60	72 60	72 60	72 60	72 60
F	48	40	40	35	30	30
1"/n	0.005"		0.010"			
C	B	35 80	50 80			
D	E	90 30	66 30			
F	100		100			

Rest Accessories

The Follow Rest (not supplied) is mainly used for cutting long and thin shaft pieces to ensure no bending takes place during cutting. It also provides a better finish surface as a result of less vibration. The Steady Rest (not supplied) provides a similar function as with the Follow Rest. The difference being that the Steady Rest is fixed on the bed guides, and does not follow the movement of the cutting tool. Both rests can be purchased from Harbor Freight Tools.

Maintenance

General

1. Unplug power cord from receptacle when not in use.
2. Using compressed air, blow off all dirt and particles after using.
3. Keep all tools sharp.
4. Cover Lathe when not in use.
5. Periodically, check all bolts and nuts for tightness.

Lubrication

Lubricate the Lathe daily using an appropriate machine oil from a forced-feed oil can.

ITEM	PART TO BE LUBRICATED	LUBE POINT
See lubrication location illustration on next page		
1	Fix bolt of intermediate gear	Oil Cup
2	Leadscrew support	Oil Cup
3	Cutter rest screw	Oil Cup
4	Cutter rest carriage	Oil Cup
5	Tailstock sleeve	Oil Cup
6	Tailstock leadscrew	Oil Cup
7	Leadscrew support	Oil Cup
8	Sync. counter-pulley over shaft	Oil Cup
9	Change gear, shaft bolt	Oil Cup
10	Change gear	Oil Cup
11	Bed guides	Oil Cup
12	Saddle Carriage	Oil Cup
13	Saddle leadscrew	Oil Cup
14	Saddle Carriage	Oil Cup
15	Bed guides	Oil Cup
16	Cutter rest leadscrew	Oil Cup
17	Apron	Oil Cup
18	Bed guides	Oil Cup
19	Saddle carriage leadscrew support	Oil Cup
20	Apron	Oil Cup
21	Bed guides	Oil Cup
22	Leadscrew	On Leadscrew

Lubrication Points

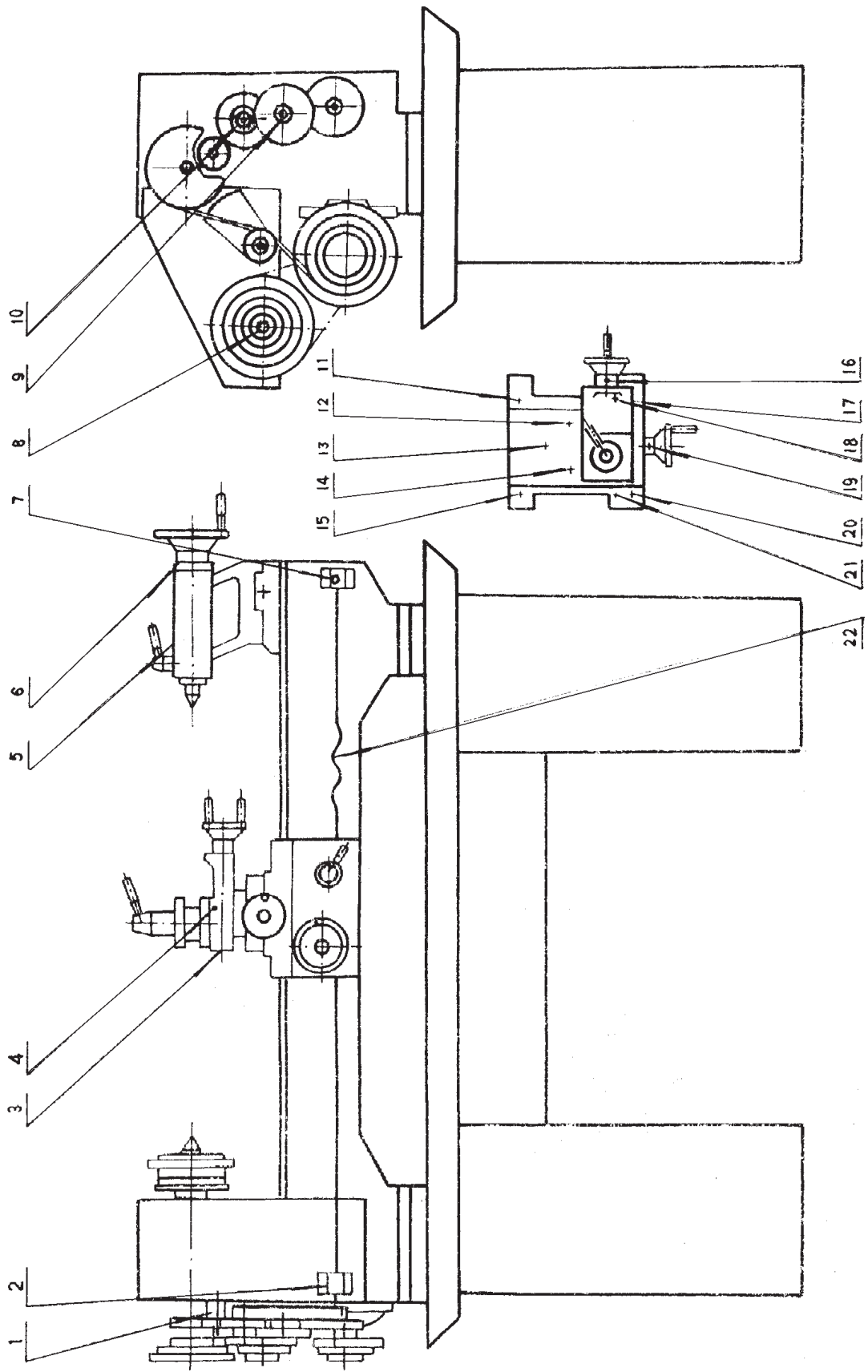

Headstock Parts List

ITEM #	NAME	QTY	REMARKS
201	Front Oil Ring	1	
202	Roller Bearing	2	35x62x17
203	Oil Ring	1	
204	Screw	4	M3x8
205	Front Panel	1	
206	Rear Oil Ring	1	
207	Tube Separator	1	
208	Spindle Pulley	1	
209	Nut	2	M27x1.5
210	Spindle Gear	1	
211	Screw	4	M5x10
212	Switch Box	1	
213	Headstock	1	
214	Plat Key	1	4x40
215	Screw	3	M8x16
216	Spindle	1	
217	Cover	1	

NOTE: Some parts are listed and shown for illustration purposes only and are not available individually as replacement parts.

PLEASE READ THE FOLLOWING CAREFULLY

THE MANUFACTURER AND/OR DISTRIBUTOR HAS PROVIDED THE PARTS DIAGRAM IN THIS MANUAL AS A REFERENCE TOOL ONLY. NEITHER THE MANUFACTURER NOR DISTRIBUTOR MAKES ANY REPRESENTATION OR WARRANTY OF ANY KIND TO THE BUYER THAT HE OR SHE IS QUALIFIED TO MAKE ANY REPAIRS TO THE PRODUCT OR THAT HE OR SHE IS QUALIFIED TO REPLACE ANY PARTS OF THE PRODUCT. IN FACT, THE MANUFACTURER AND/OR DISTRIBUTOR EXPRESSLY STATES THAT ALL REPAIRS AND PARTS REPLACEMENTS SHOULD BE UNDERTAKEN BY CERTIFIED AND LICENSED TECHNICIANS AND NOT BY THE BUYER. THE BUYER ASSUMES ALL RISK AND LIABILITY ARISING OUT OF HIS OR HER REPAIRS TO THE ORIGINAL PRODUCT OR REPLACEMENT PARTS THERETO, OR ARISING OUT OF HIS OR HER INSTALLATION OF REPLACEMENT PARTS THERETO.

Headstock Assembly Drawing

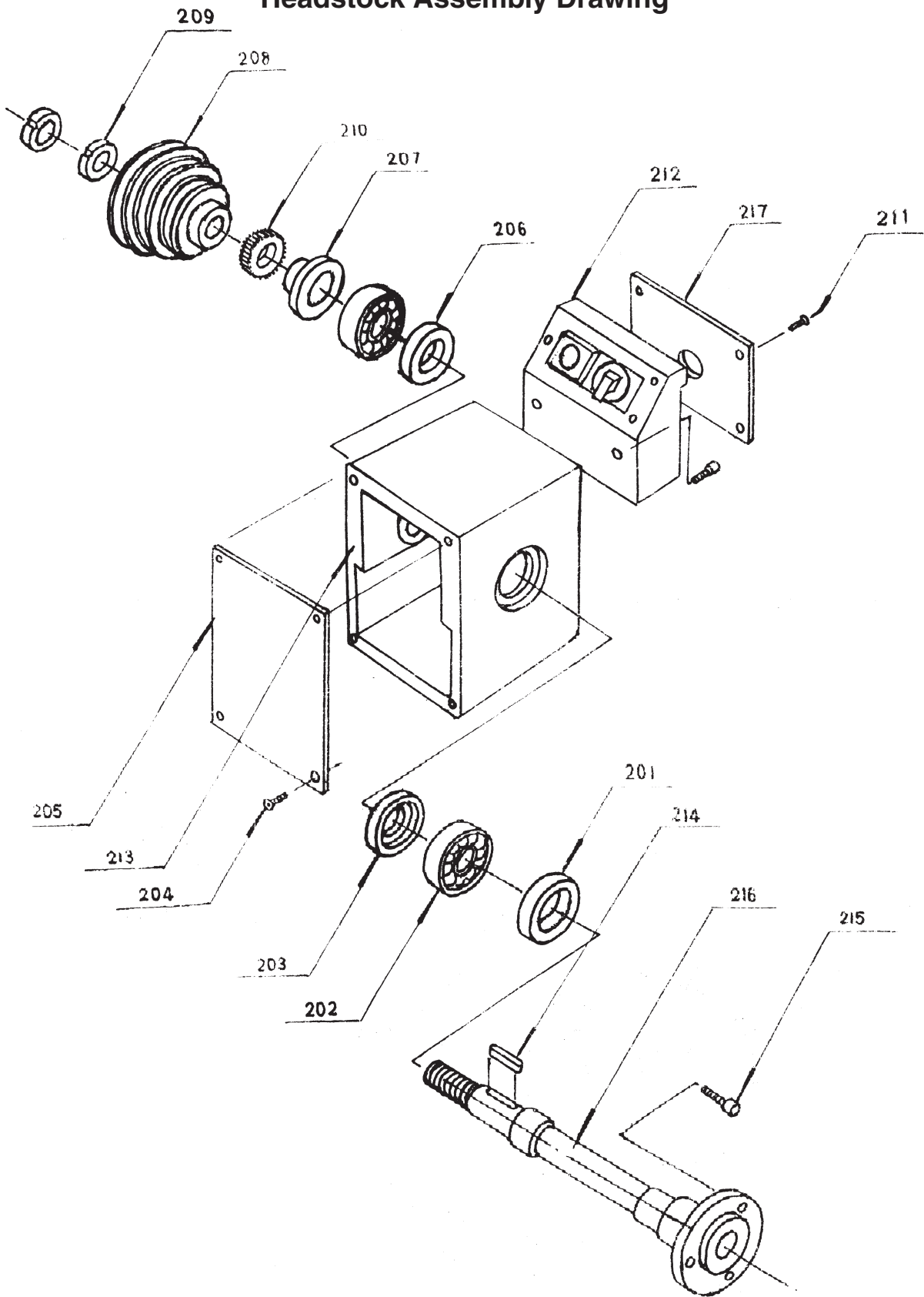

Motor and Pulley Drive Parts List

ITEM #	NAME	QTY	REMARKS
1501	Nut	3	M5
1502	Synchronized Counter Pulley	1	
1503	Slide Bearing	1	
1504	Shaft	1	
1505	Over Plate	1	
1506	Washer	1	12
1507	Washer	1	10
1508	Nut	1	M12
1509	Nut	1	M10
1510	Nut	1	M12
1511	Screw	4	M5x8
1512	Motor Guard Assembly	1	
1513	Bolt	3	M10x20
1514	Washer	1	
1515	Washer	1	
1516	Fan-Support	1	
1517	Protecting Cover Rest	1	
1518	Washer	1	8
1519	Screw	2	M5x12
1520	Synchronized Tooth Belt	1	M1.5xZ118
1521	V-Belt	1	0-710
1522	Pivot	1	
1523	Bolt	1	M8x20
1524	Bearing Arbor	1	
1525	Tension Pulley	1	
1526	Single Row Annular Bearing	2	12x28x8
1527	Check Ring	1	12
1528	Tube Separator	1	
1529	Front Feed Oil Cup	1	6
1530	Check Ring	1	12
1531	Big Washer	1	
1532	Check Ring	1	12
1533	Check Ring	1	28
1534	Front Panel	1	
1535	Cover	1	
1536	Screw	1	M5x35

1537	Check Ring	1	
1538	Motor Pulley	1	
1539	Screw	5	M5x8
1540	Check Ring	1	
1541	Synchronized Drive Pulley	1	
1542	Hinge	2	75(3")
1543	Check Ring	1	
1544	Motor	1	550W
1545	Washer	4	8
1546	Bolt	4	M8x25

Motor and Pulley Drive Assembly Drawing

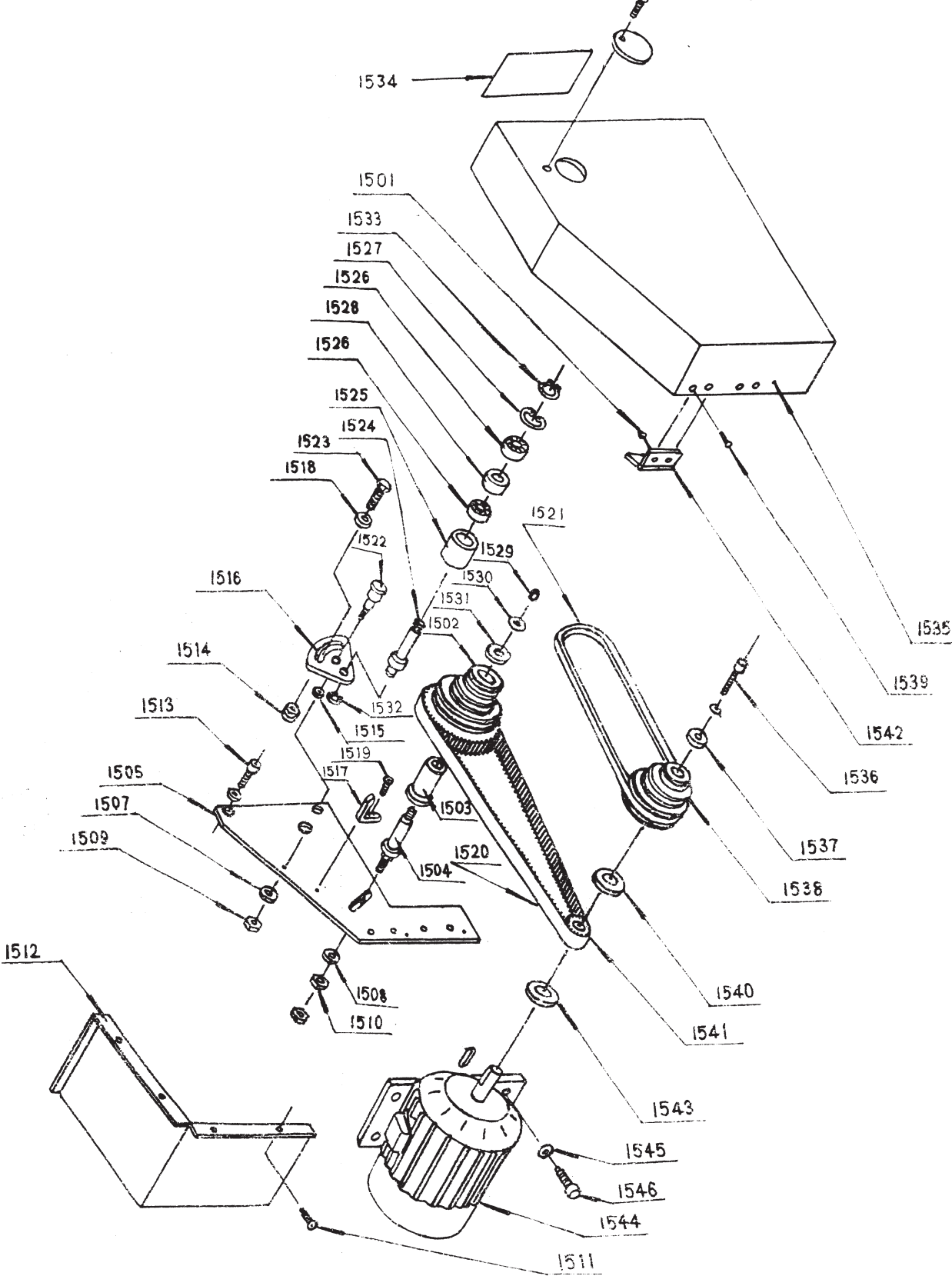

Bed Parts List

ITEM #	NAME	QTY	REMARKS
101	Left Support of Lead Screw	1	
102	Flat Key	1	4 x 6
107	Bed	1	A 400B 555
108	Screw	1	M8 x 12
109	Screw	A 4 B 5	M5 x 16
110	Oil Cup	2	
111	Right Support of Lead Screw	1	
112	Screw	1	M6 x 16
113	Laer-pin	1	6 x 22
114	Lead Screw	1	
115	Rack	1	
116	Screw	3	M4 x 16
117	Adjusting Disc	1	
118	Spring Pin	2	5 x 16

Bed Assembly Drawing

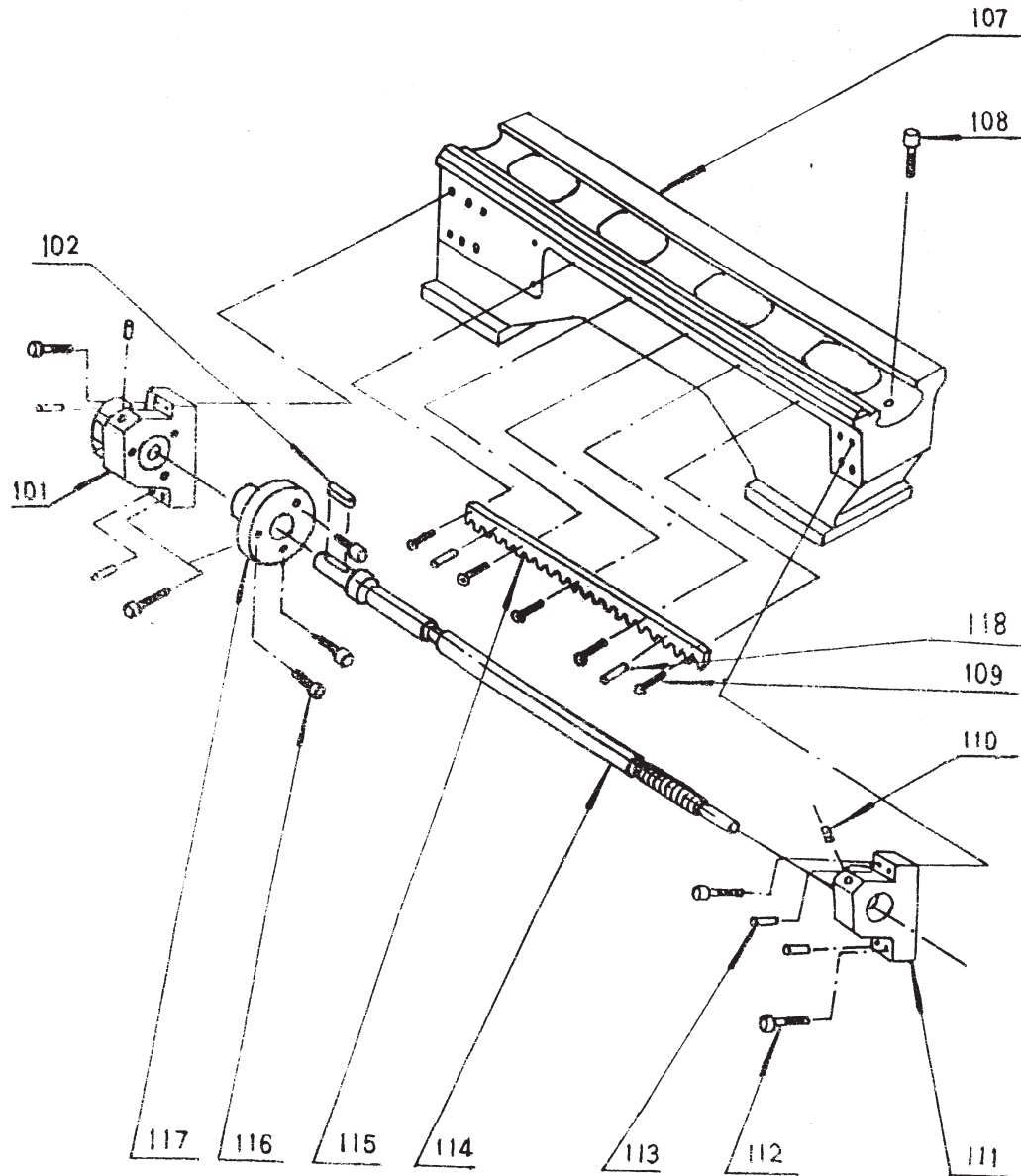

Tailstock Parts List

ITEM #	NAME	QTY	REMARKS
301	Screw	1	M8x20
303	Washer	1	B12
304	Nut	1	M12
305	Tailstock Body	1	
306	Single Row Radial Ball Bearing	1	8101
307	Tailstock Leadscrew	1	
308	Tailstock Sleeve	1	
310	Washer	1	B8
311	Bolt	1	
312	Hand Lever	1	
313	Force Feed Oil Cup	2	6
314	T-type Flat Key	1	
315	Screw	1	M8x16
316	Screw	4	M5x16
317	Tailstock End Cover	1	
318	Cylinder Pin	1	4x30
319	Spring Bow	1	
320	Handwheel	1	
321	Hand Lever Bolt	1	
322	Hand Lever Sleeve	1	
323	Index Ring	1	
324	Bolt	1	M12x80
325	Tailstock Clamp Plate	1	
326	Base	1	

Tailstock Assembly Drawing

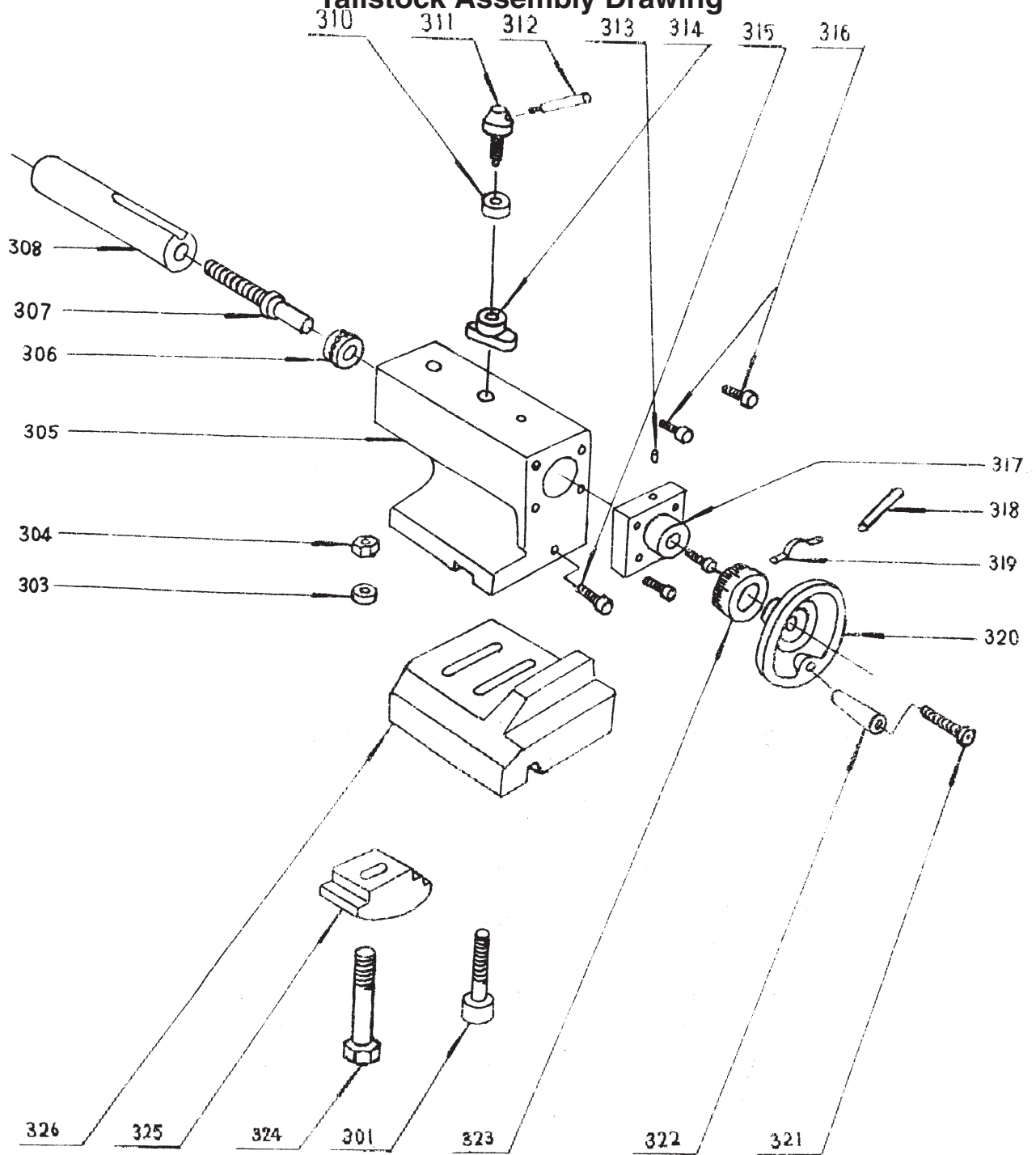

Rest Parts List

ITEM #	NAME	QTY	REMARKS
401	Nut	2	
402	Index Piece	1	
403	Rivet	2	
404	Cutter Rest Revolving Disc	1	
405	Rest Bolt	1	
406	Nut	3	M4
407	Screw	3	M4x20
408	Screw	1	M4x12
409	Nut	1	M4
410	Position Pin	1	
411	Square Cutter Rest	1	
412	Screw	8	M8x25
413	Hand Lever	1	
414	Hand Lever Base	1	
415	Washer	1	
416	Spring	1	
417	Cutter Rest Carriage	1	
418	Pad Iron	1	
419	Cylinder Pin	1	3x10
420	Cutter Rest Carriage Lead	1	
421	Flat Key	1	3x10
422	Force Feed Oil Cup	2	6
423	Leadscrew Support	1	
424	Screw	2	M5x16
425	Spring Bow	1	
426	Hand Lever	2	
427	Nut	1	M8
428	Washer	1	B8
429	Cutter Rest Carriage Hand Wheel	1	
430	Index Ring	1	
431	Screw	2	M6x22
432	Clamp Disc	1	

Rest Assembly Drawing

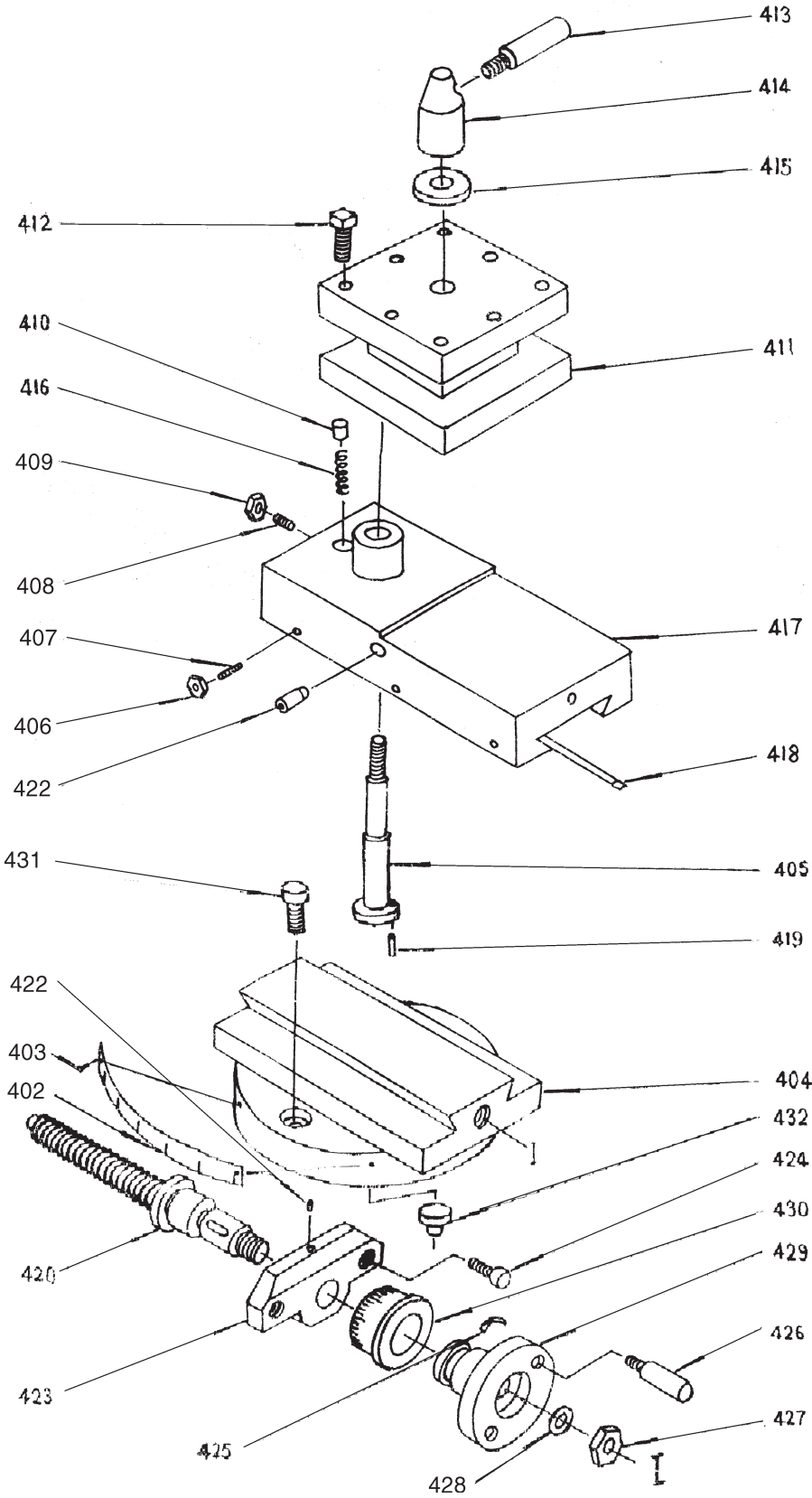

Saddle Parts List

ITEM #	NAME	QTY	REMARKS
501	Screw	1	M5x10
502	Washer	1	
503	Oil Cup	9	
504	Nut	1	
505	Middle Saddle	1	
506	Large Saddle	1	
507	Screw	4	M5x20
508	Screw	1	M8x20
509	Screw	4	M6x35
510	Protecting panel and oil-stopping falt	1	
511	Screw	2	M8x10
512	Protecting panel and oil-stopping falt	1	
513	Screw	4	M525
514	Nut	4	M5
515	Pad Iron	1	
516	Protecting panel and oil-stopping falt	1	
517	Screw	8	M3x12
518	Rear-clamp plate	1	
519	Pad Iron	1	
520	Screw	4	M5x16
521	Nut	5	M4x16
522	Screw	5	M4x16
523	Protecting panel and oil-stopping falt	1	
524	Flat Key	1	4x8
525	Screw	3	M5x22
526	Pring Bow	1	
527	Washer	1	
528	Screw	1	M6x10
529	Bracking Plate	1	
530	Saddle Front-clamp Plate	1	
531	Hand Lever Bolt	1	
532	Hand Lever Sleeve	1	
533	Hand wheel	1	
534	Rolling Bearing	1	8101
535	Index Ring	1	100 Rulled
536	Bearing Base	1	0.02mm
537	Rolling Bearing	1	8101
538	Leadscrew	1	10TPI
539	Leadscrew support	1	
540	Nut	1	10TPI
541	Screw	2	M3x16
542	Screw	2	M8x20

Saddle Assembly Drawing

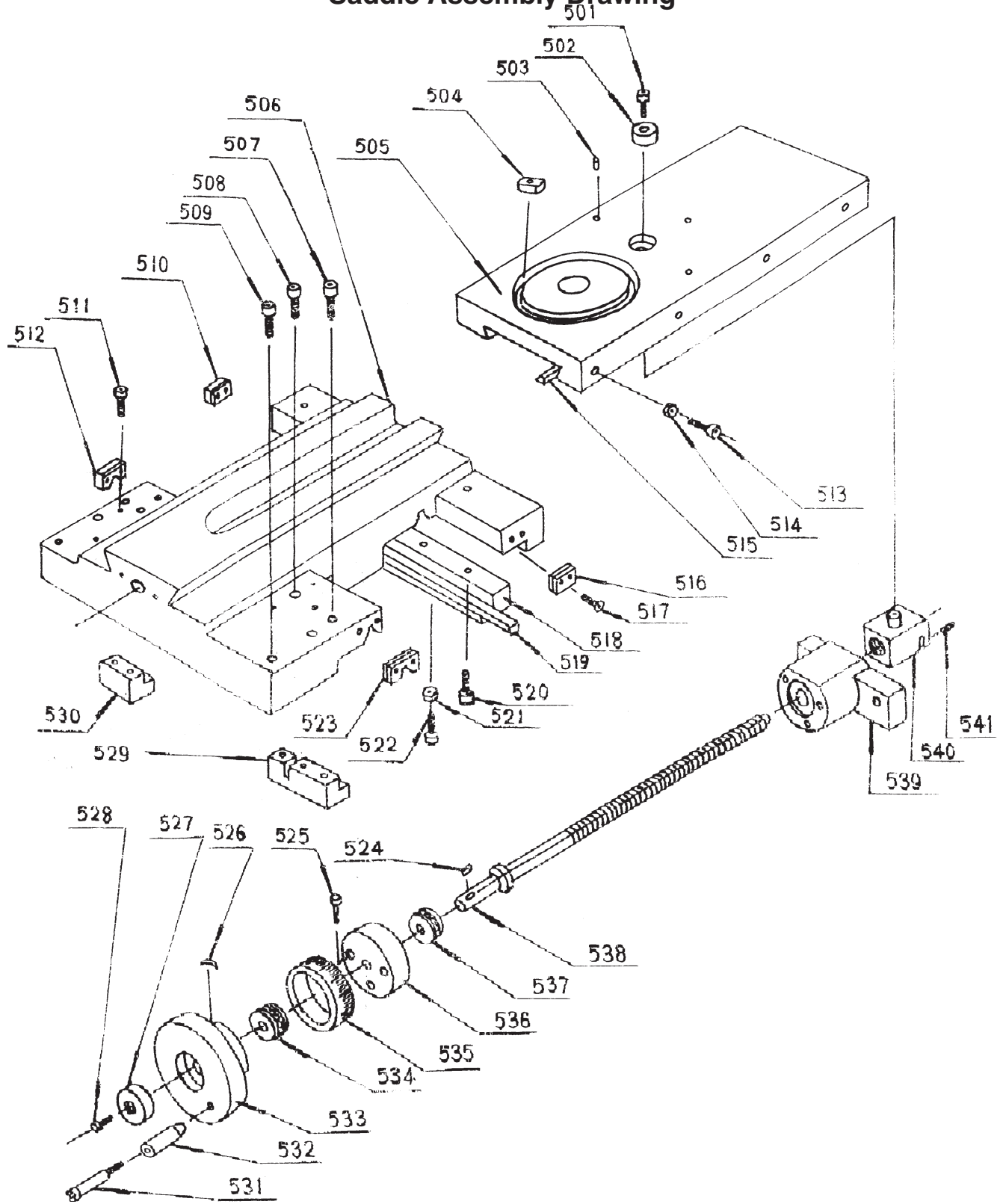

Apron Parts List

ITEM #	NAME	QTY	REMARKS
601	Slotted Disc	1	
602	Taper Pin	1	3x20
603	Shaft Sleeve	1	
604	Case	1	
605	Bolt	3	M5x30
606	Nut	3	M5
607	Revolving Shaft	1	
608	Hand Lever	1	Shared Piece
609	Steel Ball	1	5
610	Spring	1	08x5x25
611	Positioning Lever	1	
612	Screw	1	M6x10
613	Screw	1	M6x20
614	Screw	3	M4x8
615	Flanged Shaft Sleeve	1	
616	Taper Pin	1	3x30
617	Hand Lever Sleeve	1	
618	Hand Lever Sleeve	1	
619	Handwheel	1	Shared Piece
620	Screw	3	M4x8
621	Small Flanged Shaft Sleeve	1	
622	Small Gear Shaft	1	
623	Shaft Sleeve	1	
624	Gear	1	
625	Shaft Sleeve	1	
626	Flat Key	1	5x10
627	Gear Shaft	1	
628	Screw	2	M4x8
629	Nut	1	M5x30
630	Screw	1	M5x25
631	Clasp-nut	1 set	
632	Pad Iron	1	
633	Cylindrical Pin	2	5x12

Apron Assembly Drawing

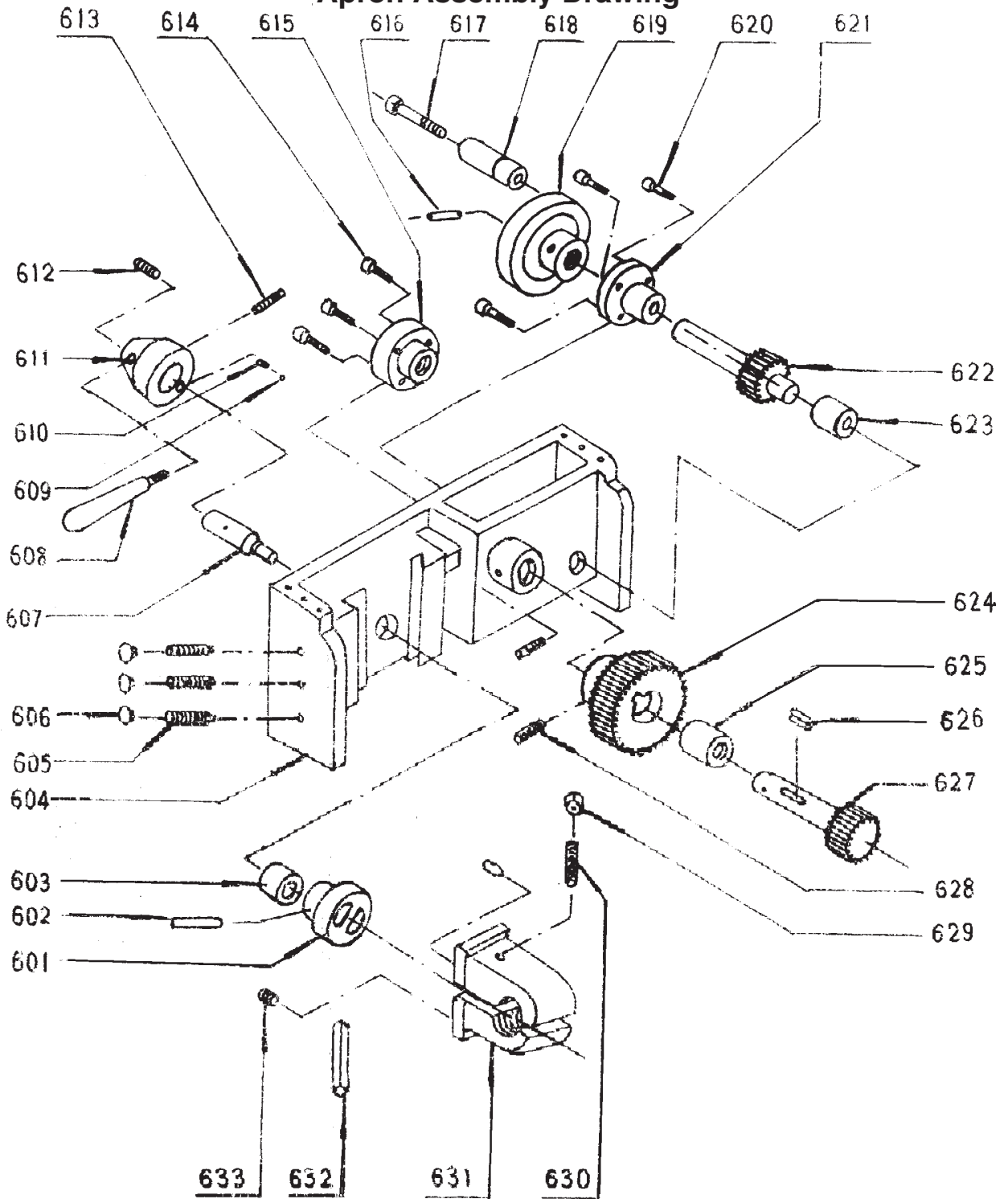

Gear Box Parts List

ITEM #	NAME	QTY	REMARKS
801	Change Gear	2	Z70
802	Change Gear	1	Z68
803	Change Gear	1	Z66
804	Change Gear	1	Z60
805	Change Gear	1	Z50
806	Change Gear	1	Z48
807	Change Gear	1	Z45
808	Change Gear	1	Z40
809	Change Gear	1	Z100
810	Washer	1	
811	Check Ring	1	6
812	Screw	1	M5x8
813	Change Gear	1	Z30
814	Change Gear	1	Z90
815	Shaft Bolt	2	
816	Nut	2	M12
817	Oil Cup	3	6
818	Change Gear	1	Z80
819	Change Gear	1	Z35
820	Open Washer	2	
821	Rolling Bearing	1	12x28x8
822	Intermediate Gear	1	Z40
823	Check Ring	1	Z12
824	Outer Washer	1	
825	Fixed Shaft Bolt	1	
826	Washer	1	10
827	Screw	2	M5x8
828	Washer	1	6
829	Screw	1	M6x10
830	Cover	1	
831	Slide Bearing	2	
832	Washer	3	
833	Change Gear Box	1	
834	Square Nut	2	
835	Screw	1	M6x35
836	Change Gear	1	Z75
837	Chang Gear	1	Z72

Gear Box Assembly Drawing

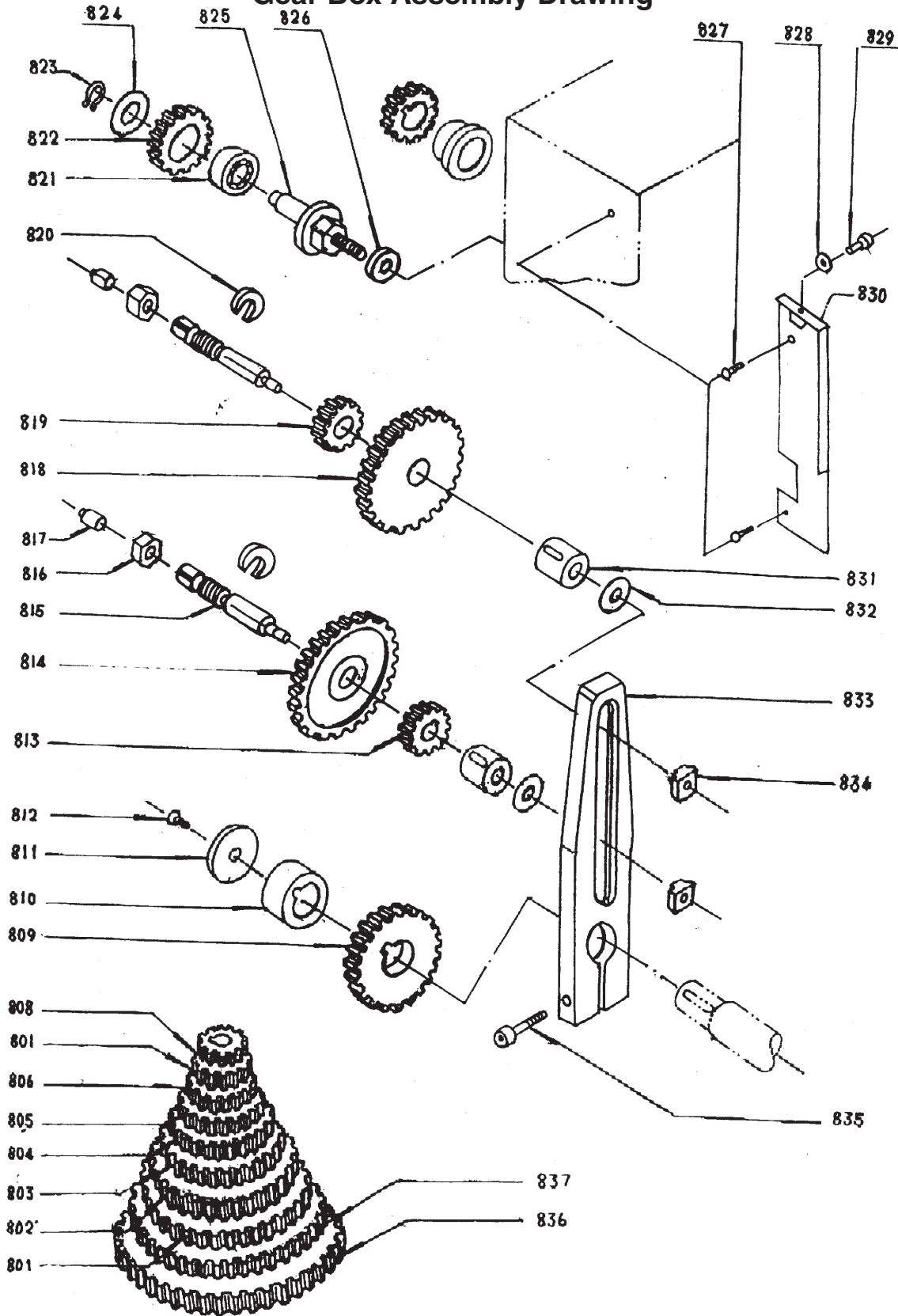

Drive System Parts List

Drive System Parts List

ITEM #	NAME	No.of Teeth	Modular Pitch	Thread Hand	Dia.of Pulley	Component No.	REMARKS
1	Synchronized Drive Pulley	19	1.5			15	
2	Change Gear	25	1			08	
3	Spindle Pulley				Ø72/102/120	02	
4	Spindle Gear	40	1			02	
6	Lead Screw		12TPI	Right		01	
8	Clearance Elimination Nut		10TPI	Left		05	
9	Carriage Leadscrew		10TPI	Left		05	
10	Cutter Rest Leadscrew		20TPI	Right		04	
11	Cutter Rest Revolving Disc		20TPI	Right		04	
12	Gear	57	1			06	
13	Rack		1.25			01	
14	Gear Shaft	17	1.25			06	
15	Clasp Nut		12TPI	Right		06	
16	Slotted Disc					06	
17	Pin					06	Gb119 76/5x12
18	Tailstock Leadscrew		10TPI	Left		03	
19	Tailstock Sleeve		10TPI	Left		03	
21	Synchronized Counter Pulley	90	1.5		Ø51/72/100	15	
22	Tension Pulley					15	
24	Intermediate Gear	40	1			08	
26	Change Gear	80	1			08	
27	Change Gear	35	1			08	
28	Change Gear	90	1			08	
28-1	Change Gear	30	1			08	
29	Change Gear	100	1			08	
30	Synchronized Tooth Belt	118	1.5			15	B=15
31	V-Belt					15	0720
32	Motor Pulley				Ø53/73/103	15	
33	Motor					15	550w
34	Pinion Shaft	17	1				06

Roller Bearing Parts List

ITEM #	NAME	Model No.	Specification	Qty	Assembly No.	REMARKS
5	Single Row Taper Roller Bearing	2007107	35x62x17	2	200	Grade D
7	Single-direction Trust Ball Bearing	8101	12x26x9	2	500	
20	Single Row Annular Bearing	8101	12x26x9	1	300	
23	Single Row Annular Bearing	101	12x28x8	2	1500	
25	Single Row Annular Bearing	101	12x28x8	1	800	

Drive System and Roller Bearing Assembly Drawing

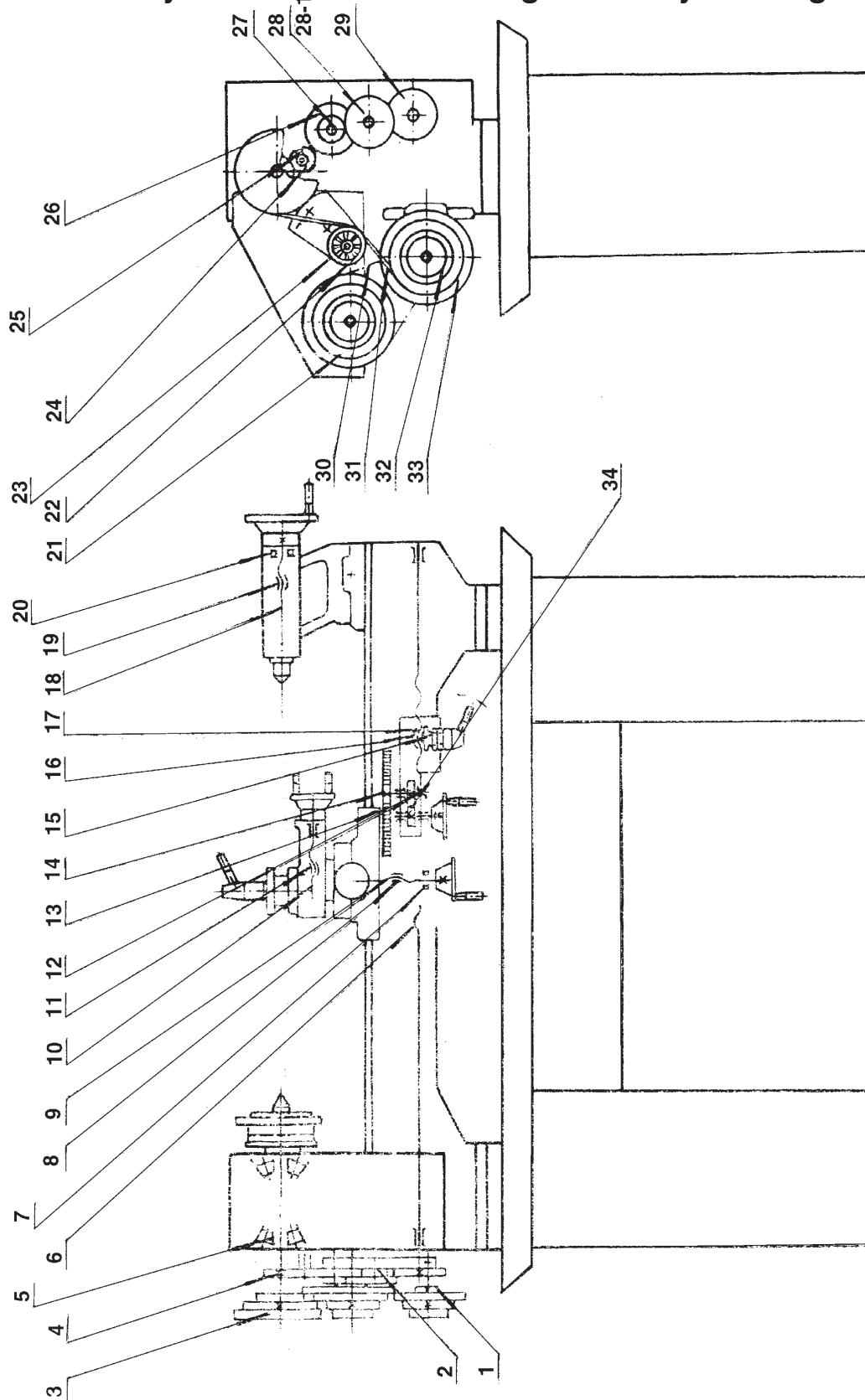

LIMITED 1 YEAR / 90 DAY WARRANTY

Harbor Freight Tools Co. makes every effort to assure that its products meet high quality and durability standards, and warrants to the original purchaser that for a period of ninety days from date of purchase that the engine/motor, the belts (if so equipped), and the blades (if so equipped) are free of defects in materials and workmanship. Harbor Freight Tools also warrants to the original purchaser, for a period of one year from date of purchase, that all other parts and components of the product are free from defects in materials and workmanship (90 days if used by a professional contractor or if used as rental equipment). This warranty does not apply to damage due directly or indirectly, to misuse, abuse, negligence or accidents, repairs or alterations outside our facilities, normal wear and tear, or to lack of maintenance. We shall in no event be liable for death, injuries to persons or property, or for incidental, contingent, special or consequential damages arising from the use of our product. Some states do not allow the exclusion or limitation of incidental or consequential damages, so the above limitation of exclusion may not apply to you. THIS WARRANTY IS EXPRESSLY IN LIEU OF ALL OTHER WARRANTIES, EXPRESS OR IMPLIED, INCLUDING THE WARRANTIES OF MERCHANTABILITY AND FITNESS.

To take advantage of this warranty, the product or part must be returned to us with transportation charges prepaid. Proof of purchase date and an explanation of the complaint must accompany the merchandise. If our inspection verifies the defect, we will either repair or replace the product at our election or we may elect to refund the purchase price if we cannot readily and quickly provide you with a replacement. We will return repaired products at our expense, but if we determine there is no defect, or that the defect resulted from causes not within the scope of our warranty, then you must bear the cost of returning the product.

This warranty gives you specific legal rights and you may also have other rights which vary from state to state.

3491 Mission Oaks Blvd. • PO Box 6009 • Camarillo, CA 93011 • (800) 444-3353

For technical questions and replacement parts, please call 1-800-444-3353